

双桶式三机一体
Double hopper 3 in 1
compact dehumidifying
dryer

**TDA
TDB**



● **特点 Features**

- 双桶式三机一体，可同时干燥两种不同的原材料，设定不同的温度。
 - 具备三机一体所有功能
 - 省能源、省空间。
- Double hopper 3 in 1 compact dehumidifying dryer.
 - Has all function of 3 in 1 compact dehumidifying dryer.
 - Saves energy, saves space.

● **TDA双桶式三机一体 TDA Double hopper 3 in 1 compact dehumidifying dryer**

机型Model	TDA-15D	TDA-25D	TDA-50D	TDA-75D	TDA-100D	TDA-200D
L(mm)	1385	1332	1332	1634	1635	1995
M(mm)	980	927	956	1060	1160	1315
H(mm)	1602	1744	2003	2167	2167	2714
D(mm)	195.5	195.5	195.5	195.5	195.5	195.5
E(mm)	420	420	420	420	420	420
F(mm)	368	368	368	370	370	370

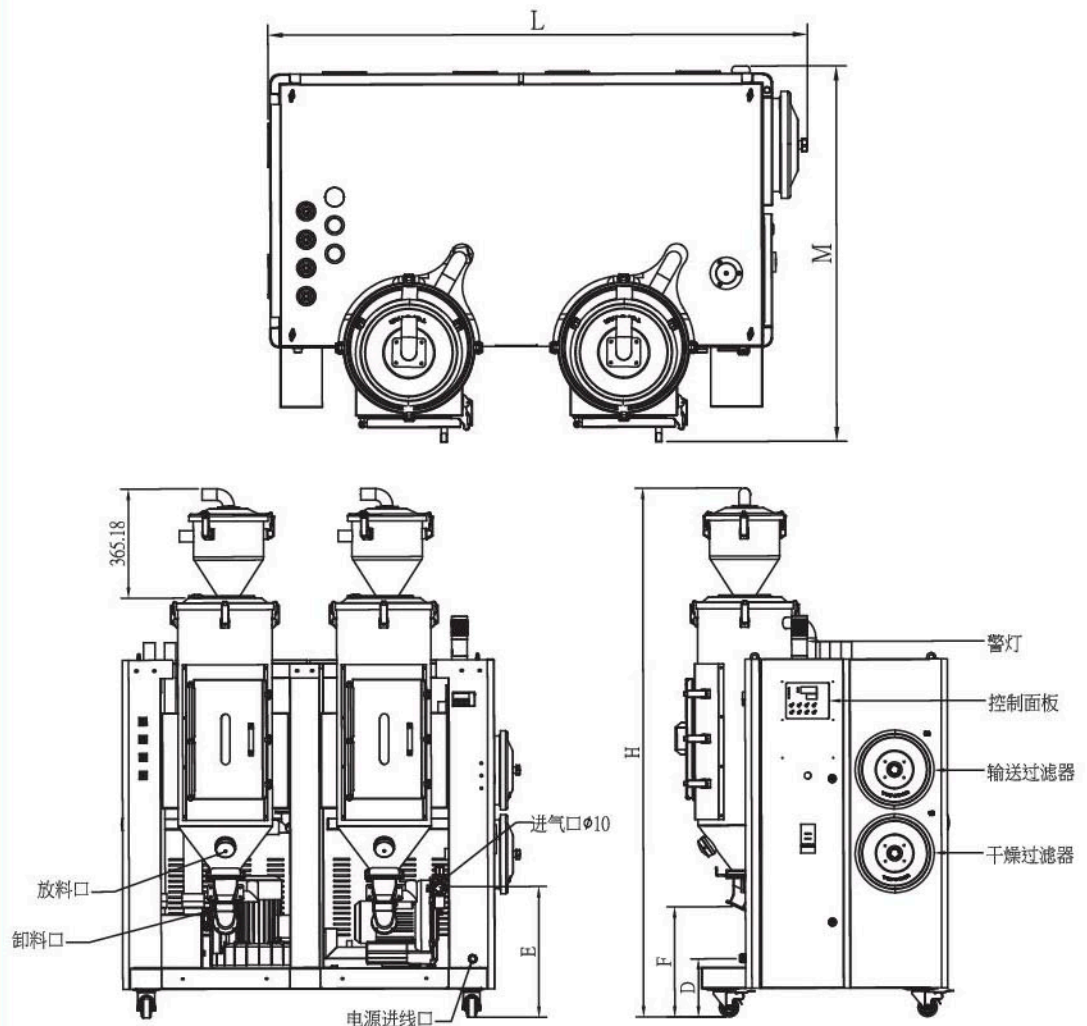

● TDB双桶式三机一体 TDB Double hopper 3 in 1 compact dehumidifying dryer

机型Model	TDB-25D	TDB-50D	TDB-75D	TDB-100D
L(mm)	1332	1332	1465	1465
M(mm)	956	956	1160	1160
H(mm)	1944	1999	1897	2160
D(mm)	195.5	195.5	195.5	195.5
E(mm)	420	420	420	420
F(mm)	368	368	370	370

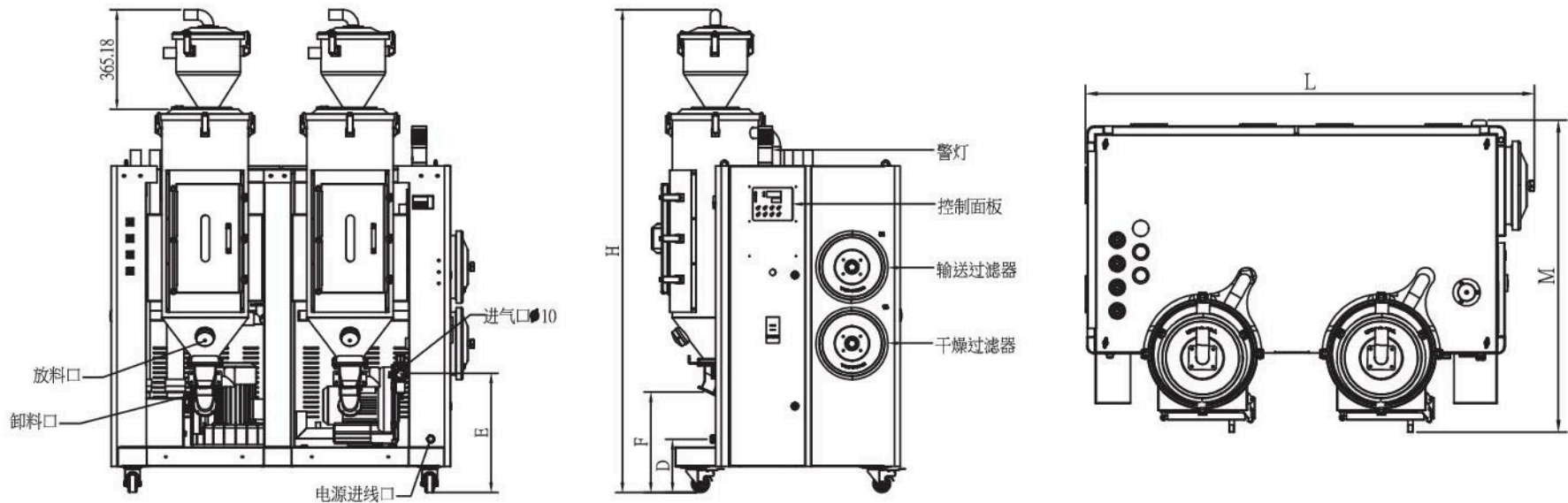

● 规格表 Specification Sheet

产品型号Model		TDA-15D	TDA-25D	TDA-50D	TDA-75D	TDA-100D	TDB-15D	TDB-25D	TDB-50D	TDB-75D	TDB-100D
除湿种类 Dehumidifying type		节能型 Energy saving type					转轮型 Homeycomb rotor type				
风量 Dehumidifying air capacity	m3/hr	25 × 2	35 × 2	50 × 2	80 × 2	100 × 2	25 × 2	35 × 2	50 × 2	80 × 2	100 × 2
露点 Dew point	℃	提供-40℃压缩空气 Supply -40℃ pressure air					-40℃				
干燥温度 Drying Temperature	℃	70-160℃									
冷却方式 Cool mode		无需冷却 don't need cool					风冷 Air cool				
干燥电热功率 Drying Heater Capacity	KW	2 × 2	2 × 2	3 × 2	3 × 2	4 × 2	2 × 2	2 × 2	3 × 2	3 × 2	4 × 2
干燥风机功率 Drying Blower Capacity	KW	0.37	0.75	1.1	1.5	2.2	0.37		1.1	1.5	2.2
再生电热功率 Regen. Heate Capacity	KW	无NONE					2		3	4	
再生风机功率 Regen Motor Capacity	KW	无NONE					0.18		0.25	0.55	
输送风机功率 Conveying Blower Capacity	KW	1.1			2.2		1.1			2.2	
系统电源 Power Supply	V	380VAC 3P/PE 50Hz									
控制电源 Control Voltage	V	220VAC 1P/PE 50Hz									
总功率 Total Power	KW	5.5	6	6.5	10	14.5	7.8	7.8	8.5	14.5	16.5
电源线规格 Wires Specifications	mm2	4 × 2.5			4 × 4	4 × 6	4 × 4			4 × 6	
电源线长度 Wires Length	M	5									
外观尺寸 Dimensions	L (m)	1385	1332	1332	1634	1635	1332	1332	1332	1465	1465
	W (m)	980	927	956	1060	1160	933	956	956	1160	1160
	H (m)	1602	1744	2003	2167	2167	1586	1944	1944	1897	2160
料管口径 Material Pipe Size	inch	1.5									
料斗(成型机上) Hopper Receiver		SR3E-40				SR6E-40	SR3E-40				SR6E-40
机器重量 Weight	KG	50	55	60	80	120	70	130	65	85	130
选配 Option		1.露点显示 Dew-point Indicators 2.旋风分离器 Cyclone Separator 3.高温 High Temperature (160℃~200℃) 4.中间料位									

注：产品规格若有变更，恕不另行通知。 We reserve right to change specifications without prior notice.